

CL - xx - xPx - G - xx - T - C - xxx - N - 00 - A - A - A - 0 - 0

Hood body material	
SW	Steel/White RAL9010
S4	SS 304
S6	SS 316L

Filter front size	
3P3	305x305
3P6	305x610
4P4	457x457
5P5	508x508
6P6	610x610
9P6	915x610
9P9	915x915
11P5	1108x508
12P6	1220x610

Filter frame height	
	MD-66 (Standard)
	MX-90
	MG-110

Air inlet size	
∅	available for:
160	3P3
200	3P3, 3P6, 4P4
250	3P6, 4P4, 5P5, 6P6
315	5P5, 6P6, 9P6, 9P9, 11P5, 12P6
355	6P6, 9P6, 9P9, 11P5, 12P6

Customization		
X	0	None (Standard)
	9	Custom

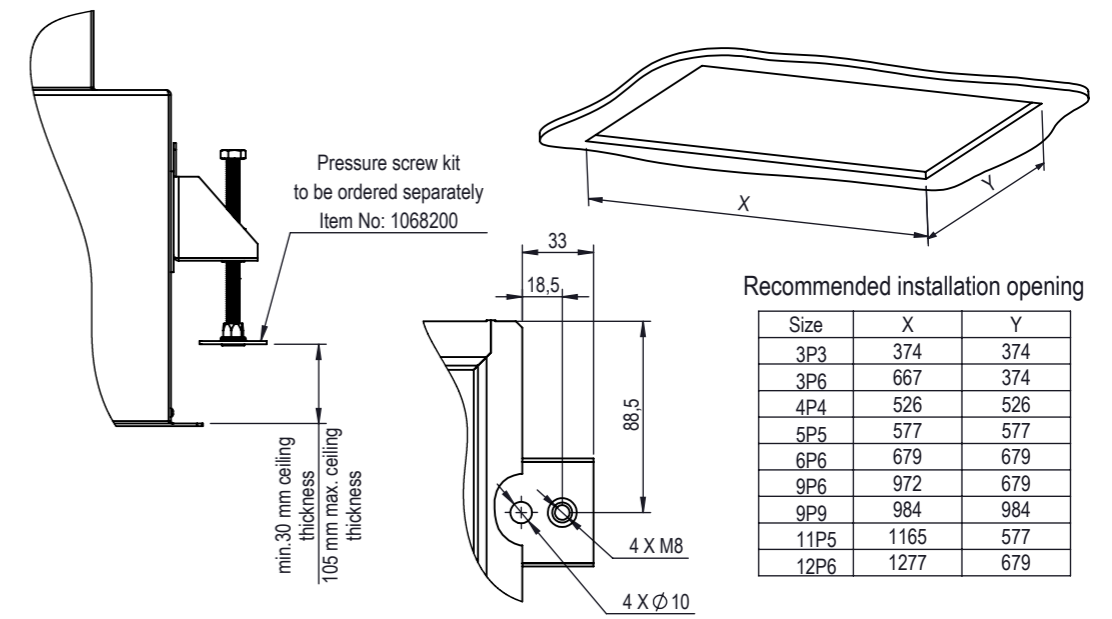

Recommended installation opening

Size	X	Y
3P3	374	374
3P6	667	374
4P4	526	526
5P5	577	577
6P6	679	679
9P6	972	679
9P9	984	984
11P5	1165	577
12P6	1277	679

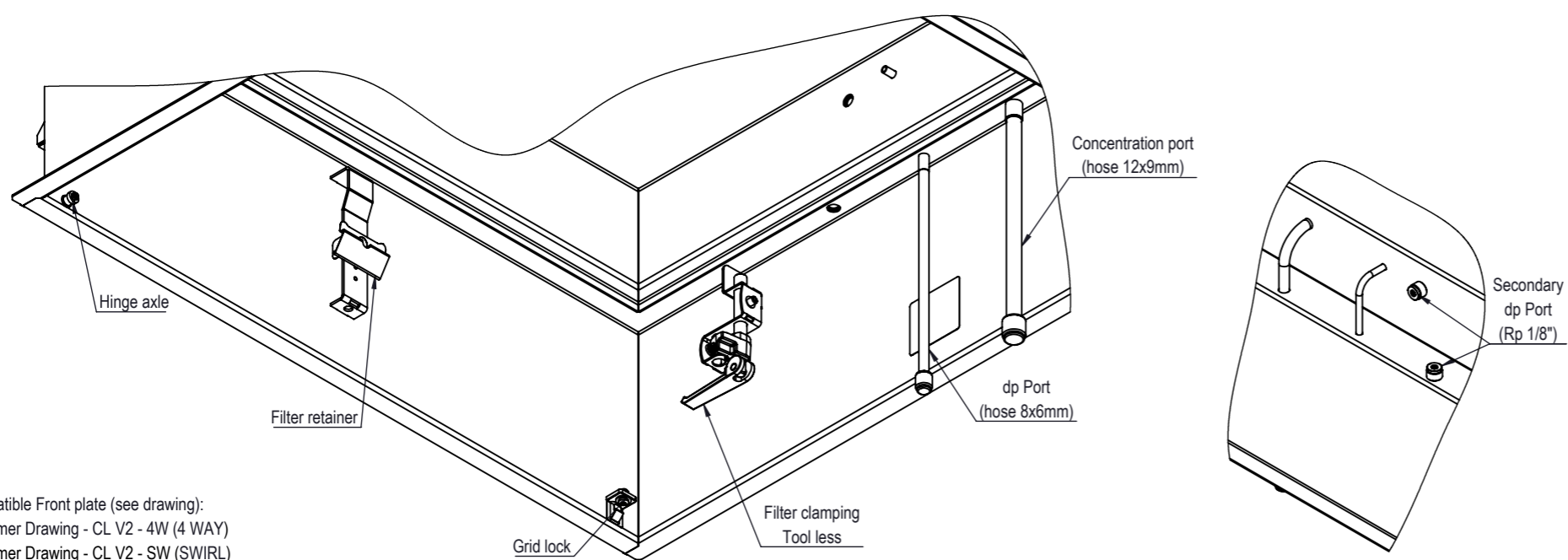
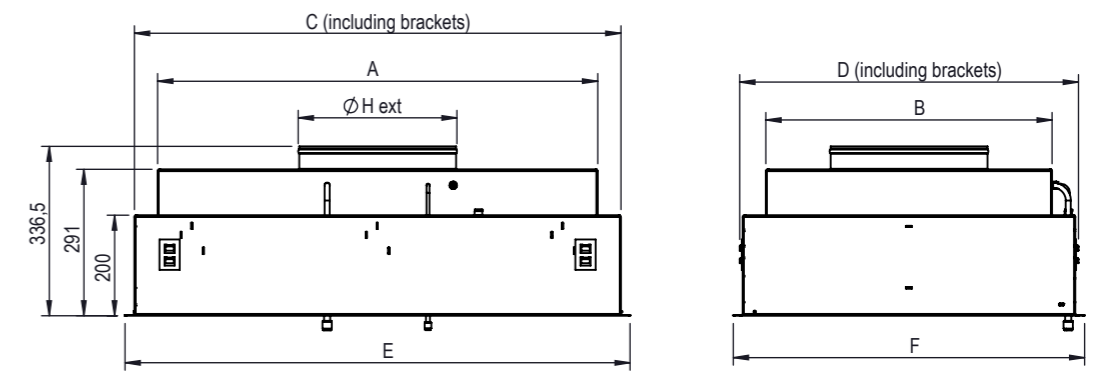
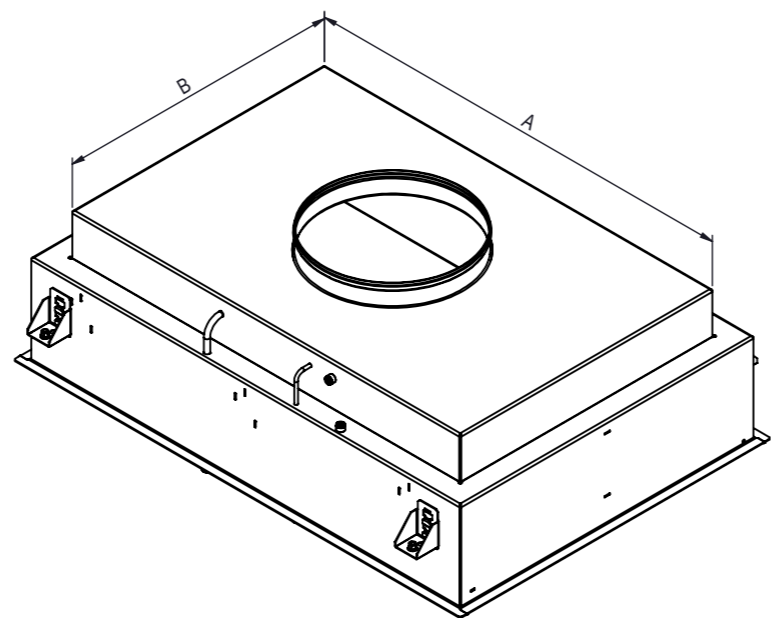
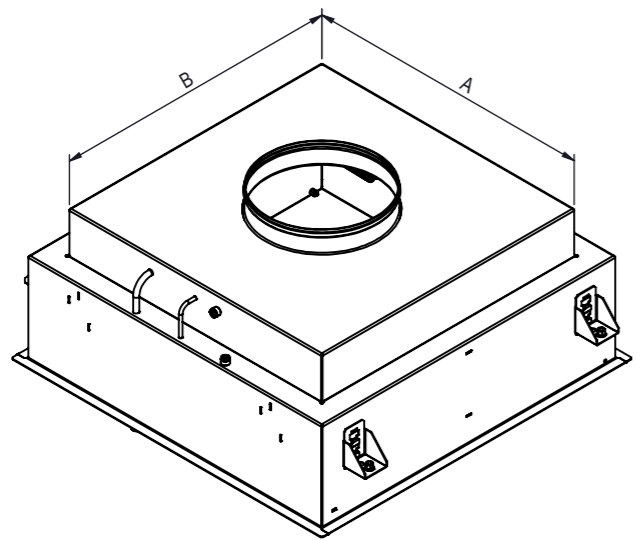

	Inlet size	CAD Reference	A	B	C	D	E	F	∅H ext	Weight [kg]
3P3	160	CL-V3-3P3-G-T-C-160	263	263	355	367	392	392	∅ 160	8
	200	CL-V3-3P3-G-T-C-200							∅ 200	
3P6	200	CL-V3-3P6-G-T-C-200	568	263	660	367	697	392	∅ 200	11
	250	CL-V3-3P6-G-T-C-250							∅ 250	
4P4	200	CL-V3-4P4-G-T-C-200	415	415	507	519	544	544	∅ 200	12
	250	CL-V3-4P4-G-T-C-250							∅ 250	
5P5	250	CL-V3-5P5-G-T-C-250	466	466	558	570	595	595	∅ 250	13
	315	CL-V3-5P5-G-T-C-315							∅ 315	
6P6	250	CL-V3-6P6-G-T-C-250	568	568	660	672	697	697	∅ 250	16
	315	CL-V3-6P6-G-T-C-315							∅ 315	
9P6	315	CL-V3-9P6-G-T-C-315	873	568	965	672	1002	697	∅ 315	27
	355	CL-V3-9P6-G-T-C-355							∅ 355	
9P9	315	CL-V3-9P9-G-T-C-315	873	873	965	977	1002	1002	∅ 315	35
	355	CL-V3-9P9-G-T-C-355							∅ 355	
11P5	315	CL-V3-11P5-G-T-C-315	1066	466	1158	570	1195	595	∅ 315	28
	355	CL-V3-11P5-G-T-C-355							∅ 355	
12P6	315	CL-V3-12P6-G-T-C-315	1178	568	1270	672	1307	697	∅ 315	33
	355	CL-V3-12P6-G-T-C-355							∅ 355	

Compatible Front plate (see drawing):
 Customer Drawing - CL V2 - 4W (4 WAY)
 Customer Drawing - CL V2 - SW (SWIRL)
 Customer Drawing - CL V2 - NZ (NOZZLES)
 Customer Drawing - CL V2 - PF (PERFORATED)
 Customer Drawing - CL V2 - AV (ADJUSTABLE - AV)
 Customer Drawing - CL V2 - SW adj (SWIRL - ABS ADJUSTABLE)

camfil
European Metal Center

DESCRIPTION: CleanSeal - GEL - Top Circular

PROJECT	LAST REVISION	WEIGHT	SCALE
DRAWING REF.	SHEET	SIZE	

PROJECT: Scope Drawing - CL-V3-G-T-C
 LAST REVISION: 11.1.2022
 SHEET: 1/2
 WEIGHT: see table
 SIZE: A3

NB: The copyright of this drawing remains with Camfil. Contents must not be used, copied or disclosed to third parties without prior written consent. All rights reserved.

CL - xx - xPx - G - xx - T - C - xxx - N - 00 - A - I - A - 0 - 0

Hood body material	
SW	Steel/White RAL9010
S4	SS 304
S6	SS 316L

Filter front size	
3P3	305x305
3P6	305x610
4P4	457x457
5P5	508x508
6P6	610x610
9P6	915x610
9P9	915x915
11P5	1108x508
12P6	1220x610

Filter frame height	
	MD-66 (Standard)
	MX-90
	MG-110

Air inlet size	
∅	available for:
160	3P3
200	3P3, 3P6, 4P4
250	3P6, 4P4, 5P5, 6P6
315	5P5, 6P6, 9P6, 9P9, 11P5, 12P6
355	6P6, 9P6, 9P9, 11P5, 12P6

Customization		
X	0	None (Standard)
	9	Custom

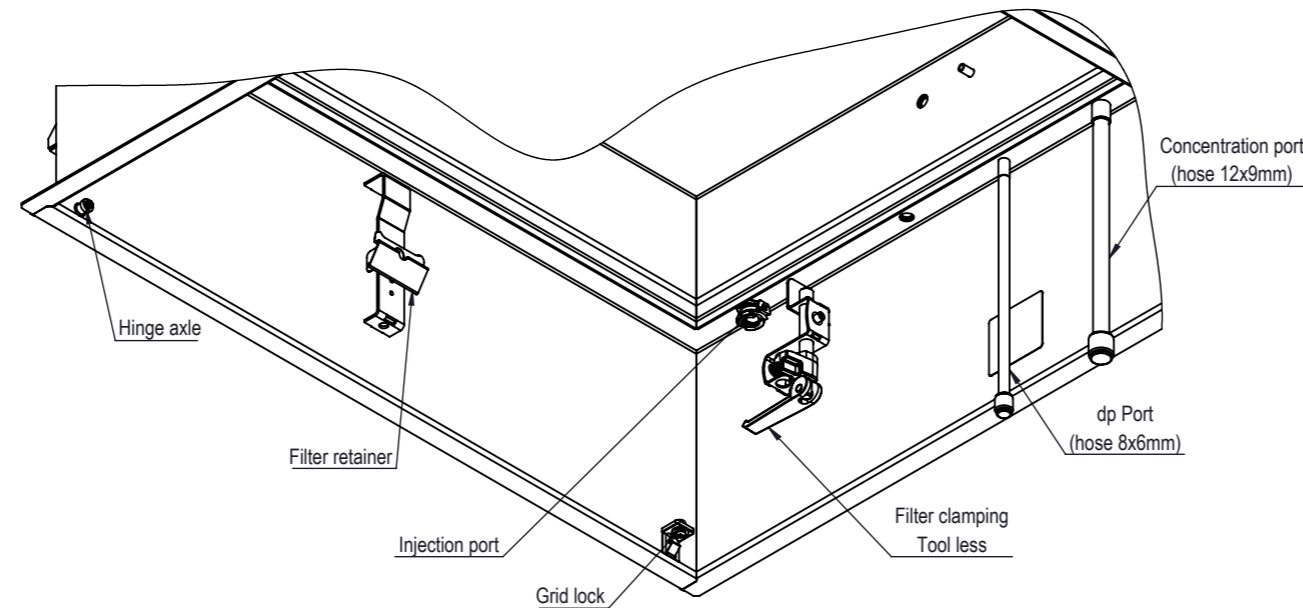
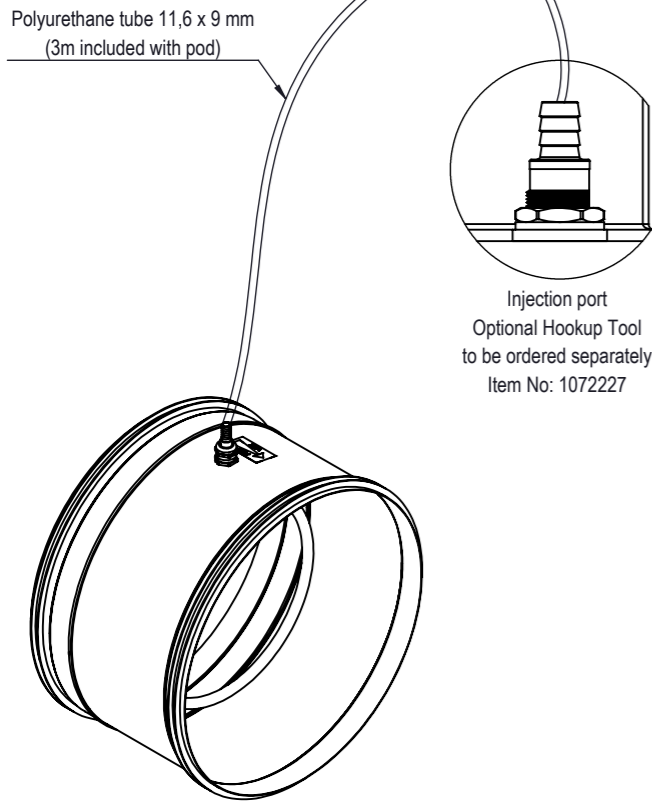
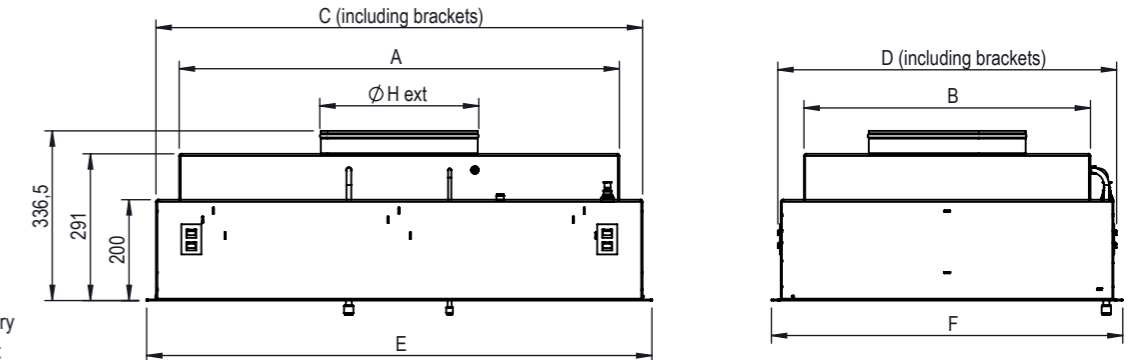
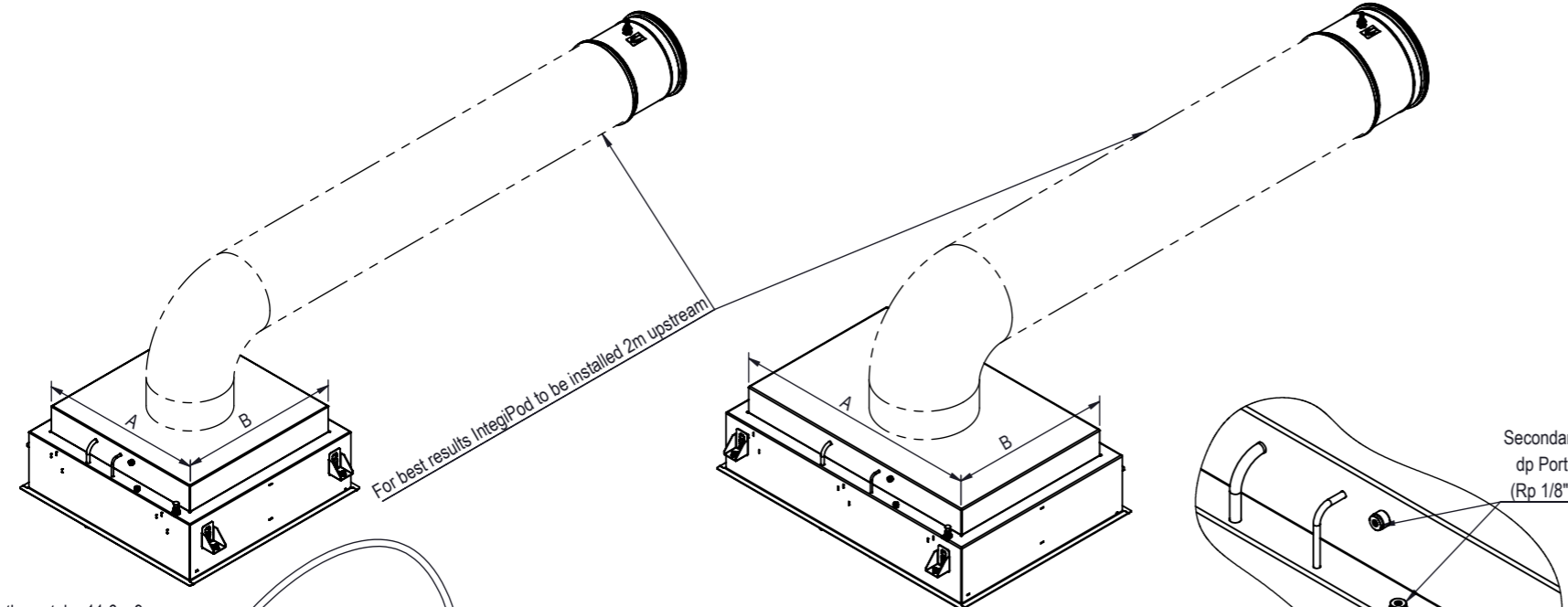
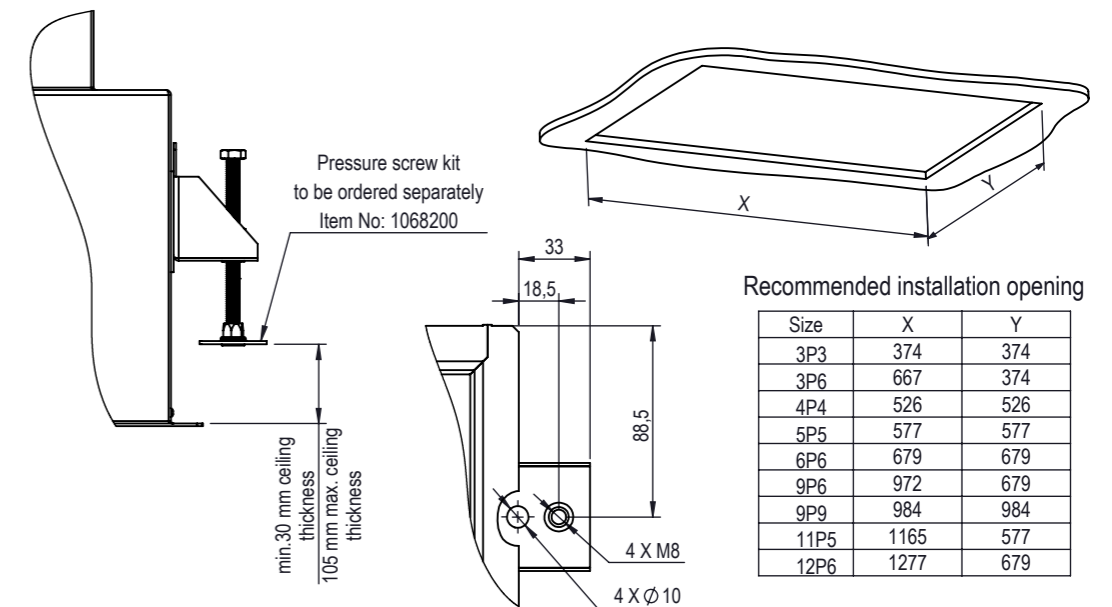

	Inlet size	CAD Reference	A	B	C	D	E	F	∅H ext	Weight [kg]
3P3	160	CL-I-V3-3P3-G-T-C-160	263	263	355	367	392	392	∅160	8
	200	CL-I-V3-3P3-G-T-C-200							∅200	
3P6	200	CL-I-V3-3P6-G-T-C-200	568	263	660	367	697	392	∅200	11
	250	CL-I-V3-3P6-G-T-C-250							∅250	
4P4	200	CL-I-V3-4P4-G-T-C-200	415	415	507	519	544	544	∅200	12
	250	CL-I-V3-4P4-G-T-C-250							∅250	
5P5	250	CL-I-V3-5P5-G-T-C-250	466	466	558	570	595	595	∅250	13
	315	CL-I-V3-5P5-G-T-C-315							∅315	
6P6	250	CL-I-V3-6P6-G-T-C-250	568	568	660	672	697	697	∅250	16
	315	CL-I-V3-6P6-G-T-C-315							∅315	
	355	CL-I-V3-6P6-G-T-C-355							∅355	
9P6	315	CL-I-V3-9P6-G-T-C-315	873	568	965	672	1002	697	∅315	27
	355	CL-I-V3-9P6-G-T-C-355							∅355	
9P9	315	CL-I-V3-9P9-G-T-C-315	873	873	965	977	1002	1002	∅315	35
	355	CL-I-V3-9P9-G-T-C-355							∅355	
11P5	315	CL-I-V3-11P5-G-T-C-315	1066	466	1158	570	1195	595	∅315	28
	355	CL-I-V3-11P5-G-T-C-355							∅355	
12P6	315	CL-I-V3-12P6-G-T-C-315	1178	568	1270	672	1307	697	∅315	33
	355	CL-I-V3-12P6-G-T-C-355							∅355	

IntegriPod included according to housing spigot diameter

camfil European Metal Center

CleanSeal Integrity - GEL - Top Circular

PROJECT	LAST REVISION	WEIGHT	
DRAWING REF.	SHEET	SIZE	
Scope Drawing - CL-V3-G-T-C	2/2	A3	SCALE

NB: The copyright of this drawing remains with Camfil. Contents must not be used, copied or disclosed to third parties without prior written consent. All rights reserved.